



Modular Holding Bin

Prince Castle's latest holding innovation provides operators the greatest flexibility for menu variety and kitchen design. Modular individually heated bins controlled by a master base, allows the system to expand horizontally and vertically, distributing power and communications to set and maintain desired serving temperatures. Modular bins can be configured and expanded as your business grows, controlling safe and consistent heating temperatures. Designed to ensure customers are always served the highest quality meals.



Product Features

- Configurable (horizontally and vertically) to tailor to the specific configuration needs
- Expandable by one unit increments (horizontal and/ or vertical) for existing and future product expansion
- Units may configured up to 5 wide and 5 high providing total installation flexibility
- Expands up to 8 total modules on a single 110-240v circuit
- Independently customize each modules product temperature and time for a wide variety of products and multiple day parts
- PC application provided for simple menu programing and uploads through the easily accessible USB port
- 1 year - Parts and Labor Warranty



A Marmon/Berkshire Hathaway Company

© 2018 Prince Castle LLC - Specifications and design are subject to change without notice

This product is patent protected. Patent information can be found at www.princecastle.com/patents/.



355 E. Kehoe Blvd.
Carol Stream, IL 60188

1.800.PCASTLE • 630.462.8800
www.princecastle.com

Dimensions

Model Number	Width in (cm)	Height in (cm)	Depth in (cm)	Shipping Weight lbs (kg)
MHB100HM1	10.28 (26.11)	4.11 (10.44)	13.76 (34.95)	10.00 (4.54)
MHB100HM2	10.28 (26.11)	4.11 (10.44)	13.76 (34.95)	10.00 (4.54)
MHB100MB	10.28 (26.11)	2.50 (6.35)	13.76 (34.95)	10.00 (4.54)
MHB100EB	10.28 (26.11)	2.50 (6.35)	13.76 (34.95)	10.00 (4.54)
Top Cover	10.28 (26.11)	1.35 (3.43)	13.76 (34.95)	Included with Main and Expansion Base



Electrical

Model Number	Description	Volts	Hz	Watts	Amps	Plug
MHB100MB-NA	Main Base, (Includes top cover), N. America	120	50/60	115-1450	12	NEMA 5-15P
MHB100MB-CE	Main Base, (Includes top cover), Worldwide Vers	200-240	50/60	115-1450	7	Shuko CEE 7/7
MHB100EB	Expansion Base (Includes top cover), N. America	120	50/60	0	-	-
MHB100EB-U	Expansion Base (Includes top cover), Worldwide Vers.	100-240	50/60	0	-	-
MHB100HM1	Pass through Holding Module, Modular (Includes one pan cover) N. America Vers. (-SS, for single side)	120	50/60	180	-	-
MHB100HM2	Pass through Holding Module, Modular (Includes one pan cover) Worldwide Vers. (-SS, for single side)	200-240	50/60	115-180	-	-

Accessories

Model Number	Description
541-1095s	1/3 Size x 2.5" Single Handle Pan
541-1095-1s	1/3 Size x 2.5" Dual Handle Pan



541-1095-1s



541-1095s

Specifications

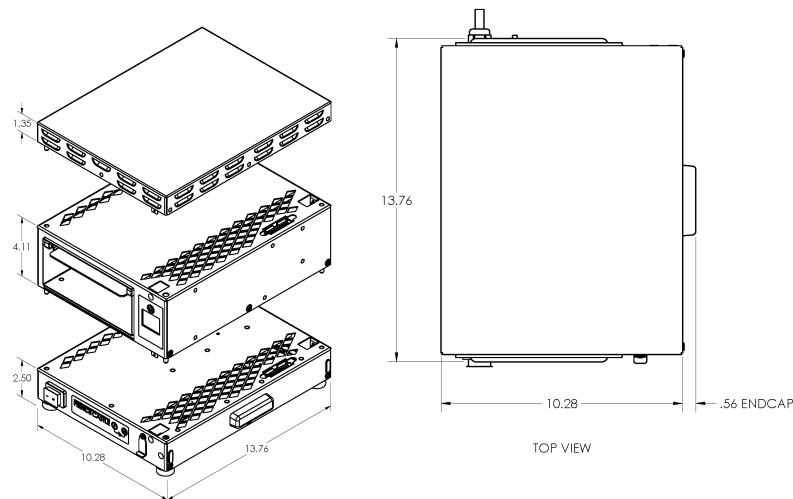

Certifications



355 E. Kehoe Blvd.
Carol Stream, IL 60188

1.800.PCASTLE • 630.462.8800
www.princecastle.com



A Marmon/Berkshire Hathaway Company

© 2018 Prince Castle LLC - Specifications and design are subject to change without notice

This product is patent protected. Patent information can be found at www.princecastle.com/patents/.

12/2018